

NEBN-PG

圆形
Thread enlarger

+200°C +392°F
-60°C -76°F

材料: 铜镀镍
Material: brass nickel-plated



- PG制螺纹扩展头
- 适配FIPLOCK® ONE PG制螺纹接头
- thread enlargers with PG threads
- suitable for FIPLOCK® ONE fittings with PG threads



产品号 Part No. ¹⁾	外螺纹 Outer thread	内螺纹 Inner thread	尺寸 Dimensions in mm						重量 Weight	包装单元 PU
			Ø L1	Ø L2	Ø A	Ø B	C	D		
NEBN-P07/P09S	PG7	PG9	5	7	17,0	10,0	15,0	10,0	4,4	10
NEBN-P09/P11S	PG9	PG11	6	7	20,0	12,5	16,5	10,5	6,6	10
NEBN-P09/P13S	PG9	PG13	6	7,5	22,0	12,5	17,5	11,5	10,1	10
NEBN-P11/P13S	PG11	PG13	6	7,5	22,0	15,0	17,5	11,5	4,6	10
NEBN-P11/P16S	PG11	PG16	6	7,5	24,0	15,0	18,5	12,5	10,1	10
NEBN-P13/P16S	PG13	PG16	6,5	7,5	24,0	17,0	19,0	12,5	5,8	10
NEBN-P13/P21S	PG13	PG21	6,5	8,5	30,0	17,0	21,0	14,5	25,6	10
NEBN-P16/P21S	PG16	PG21	6,5	8,5	30,0	18,5	21,0	14,5	19,1	10
NEBN-P16/P29S	PG16	PG29	6,5	9	39,0	18,5	22,5	16,0	63,5	10
NEBN-P21/P29S	PG21	PG29	7	9	39,0	24,0	23,0	16,0	41,7	6
NEBN-P29/P36S	PG29	PG36	8	15,5	50,0	32,0	27,5	19,5	72,8	6
NEBN-P36/P42S	PG36	PG42	9	15	57,0	42,0	21,0	22,0	68,8	4
NEBN-P36/P48S	PG48	PG48	10	17	64,0	48,0	33,0	23,0	130,7	4

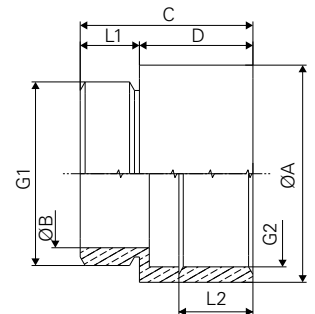

您可以通过以下地址查询更多的技术信息 / You can find more technical information here

CADENAS – 产品CAD数据目录 / eCATALOG solutions electronic CAD catalog: <https://fraenkische-ip.partcommunity.com>

¹⁾ FIPLOCK® 附件编码规则 / Part numbering key for FIPLOCK® accessories: www.fraenkische-ip.com/fiplock-accsy-part-no



NEBN-PG 产品性能 / Product performances

应用性能 <i>Application performances</i>	特性 <i>Characteristics</i>	单位 <i>Unit</i>	规范标准 <i>Standards, specifications</i>	备注 <i>Remark</i>
温度范围 / <i>Temperature range</i>	-60 到 / <i>to</i> +200 -76 到 / <i>to</i> +392	°C °F	IS FIP	

测试条件参照EN ISO 139 , 温度 23°C / 湿度50% r. h. (如未注明测试条件). IS FIP = FIP内部测试规范
Tests carried out acc. EN ISO 139 at 23°C / 50% r. h. (if not indicated differently). IS FIP = Internal Specification FIP

我们尽我们的知识水平所提供的数据, 图片和技术规格图档反映了当前的工程技术水平。这不包含对最后应用有关的任何责任。产品用户需根据应用要求自行进行评估。以确定产品是否符合特殊应用条件。我们对产品的责任只考虑一般规定条件下的水平。FIP保留对产品数据和数值进行技术调整的权利。例如更改材料和加工工艺, 在保证产品性能数值不下降的情况下不会另行通知。

The provided data, images and technical specification drawings reflect the current engineering level and are to the best of our knowledge. This does not include any liability regarding the final application. Users of the products have to make their own evaluation to determine the suitability for a specific application. Our liability for these products considers the stated level within our General Conditions only. FRAENKISCHE Industrial Pipes (FIP) reserves the right to adjust specified data and values as well as implementing technical adjustments of the products e. g. change of materials and processing technologies without prior notice as long as the specified values are not reduced.